

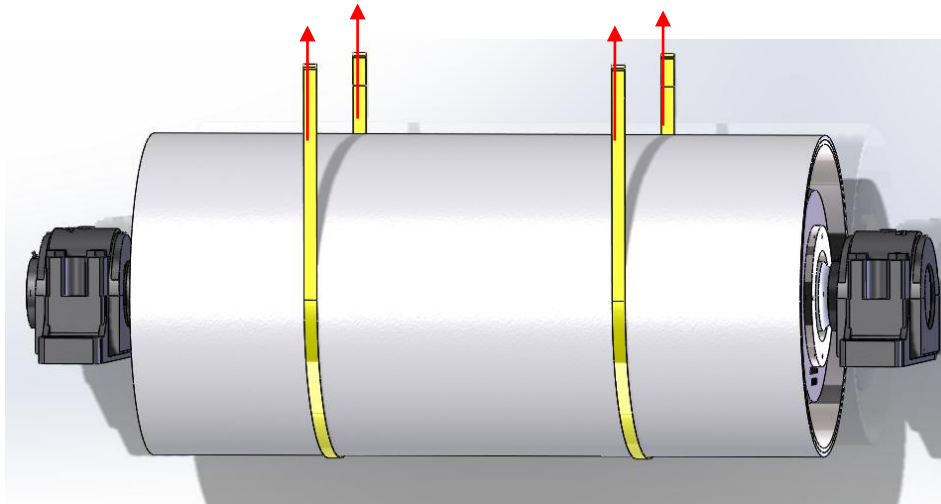

Pulley Installation and Handling



⚠ WARNING

Pulleys will usually be delivered on skids or cradles. Pulleys can be handled on packaging if fork trucks are rated for the weight capacity and forks are extended the full length through the packaging.

When lifting the pulleys, use of weight-rated nylon strap is recommended. Use of other material rope, chain, or strapping can and has been proven to risk both damage to the pulley and possible harm to others due to weight-support failure.

Pulley assemblies may be asymmetrical with uneven weight distribution. Ensure even weight load when lifting. If possible, lift from pulley's shell (rim). If another location is needed for lifting, strap around shafting away from any shaft journals, bearings, or bearing seals.

