

Van Gorp®

The Take-Up Place

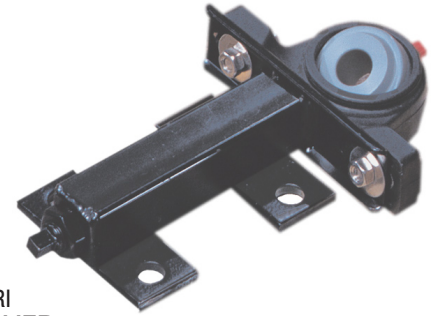
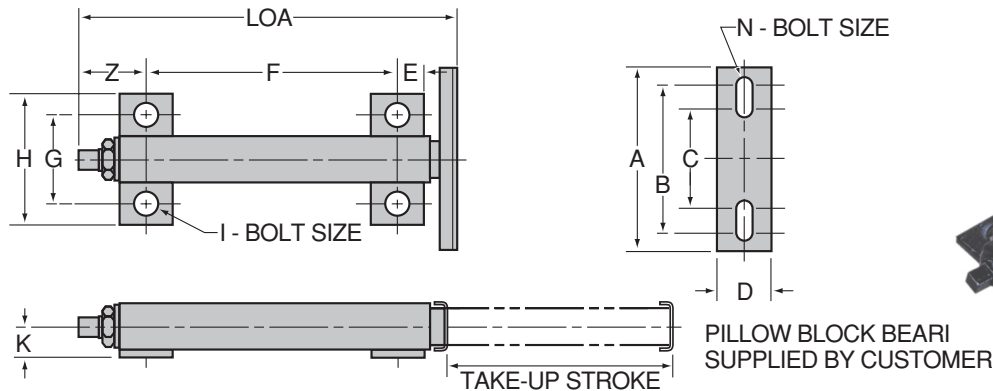

PILLOW BLOCK BEARING
SUPPLIED BY CUSTOMER

Telescoping Take-up Frame

HOW TO SPECIFY AND ORDER						STANDARD TAKE-UP DIMENSIONS (INCHES)																	
BEARING BORE RANGE	TUBE SERIES	TAKE UP STROKE	MATERIAL	MTG. FEET	BEARING PLATE	LOA	K	BEARING PLATE DIMENSIONS					FOOT DIMENSIONS					SQ. TUBE SIZE		ADJUSTER			
								A	B	C	D	N BOLT	E	F	G	H	I BOLT	Z	SLIDER	BODY	SQ DRIVE	THD. UNC.	
1/2" TO 1"	100	3	MS	SF	BP	6.88	0.88	5.25	4.31	2.94	1.50	3/8	0.75	3.56	2.63	3.69	1/2	1.84	1.00	1.25	WELD NUT 15/16 HEX	.625-11	
		6				10.38								7.06									11.06
		9				14.38								11.06									11.06
3/4" TO 1 3/4"	250	3	MS	SF	BP	8.50	1.13	7.00	5.69	3.81	2.04	1/2	1.00	4.38	3.00	4.00	1/2	2.25	1.50	1.75	WELD NUT 1 1/8 HEX	.75-10	
		6				11.50								7.38									10.38
		9				14.50								10.38									13.38
		12				17.50								13.38									13.38
1 3/4" TO 2 15/16"	300	6	MS	SF	BP	11.13	1.50	10.00	8.69	5.56	2.84	5/8	1.25	6.12	4.00	5.25	5/8	2.63	2.25	2.50	WELD NUT 1 5/16 HEX	.875-9	
		9				15.13								10.12									14.12
		12				19.13								14.12									21.12
		18				26.13								21.12									21.12
1 3/4" TO 2 15/16"	350 HD	9	MS	SF	BP	19.00	1.75	10.00	8.69	5.56	3.00	5/8	1.25	13.00	4.50	5.75	5/8	3.50	2.50	3.00	WELD NUT 1 7/16 HEX	.875-6 ACME	
		12				22.00								16.00									22.00
		18				28.00								22.00									28.00
		24				34.00								28.00									28.00
2 7/16" TO 3 1/2"	400	12	MS	SF	BP	27.75	2.13	14.00	11.75	8.50	3.50	3/4	1.75	20.00	5.50	7.50	3/4	4.25	3.00	3.50	WELD NUT 2 HEX	1.25-5 ACME	
		18				33.75								26.00									32.00
		24				39.75								32.00									32.00

Easy 4-bolt assembly to channel bed

Uses standard 2-bolt pillow block bearing on pillow block bearings

Sturdy, simple modular design for troublefree operation

Threaded internal adjuster rod is totally enclosed and protected against product buildup, rust, corrosion, or thread damage.

CALL 1-800-VAN-GORP (826-4677) for all of your Take-Up needs! Or email vangorp@vangorp.biz

World Class Quality



Top Mount Take-up Frame

UNIT DIMENSIONS:				TUBE SIZES			ADJUSTER ROD SIZES
MODEL	TAKE UP STROKE	A	B	BT	TS1	TS2	
350TM	9	28.75	26.00	3.00	3.50	2.50	.875-6 ACME
	12	31.75	29.00				
	18	37.75	35.00				
	24	43.75	41.00				
	30	49.75	47.00				
	36	55.75	53.00				
400TM	9	34.25	31.50	3.50	4.00	2.75	1.250-5 ACME
	12	37.25	34.50				
	18	43.25	40.50				
	24	49.25	46.50				
	30	55.25	52.50				
	36	61.25	58.50				
500TM	9	51.75	46.75	6.00	7.00	5.00	2.250-4 ACME
	12	54.75	49.75				
	18	60.75	55.75				
	24	66.75	61.75				
	30	72.75	67.75				
	36	78.75	73.75				

MOUNTING DIMENSIONS										
MODEL	FA	FB	FC	FD	FE	FF	FG	FH	FJ	FK
350TM	3.00	1.63	4.00	2.50	0.75	0.75	2.00	4.00	5.25	1.24
400TM	3.50	2.13	5.00	3.00	1.00	0.88	2.82	5.00	6.50	1.36
500TM	6.00	3.50	7.50	5.00	1.25	0.88	4.25	8.00	9.93	1.76

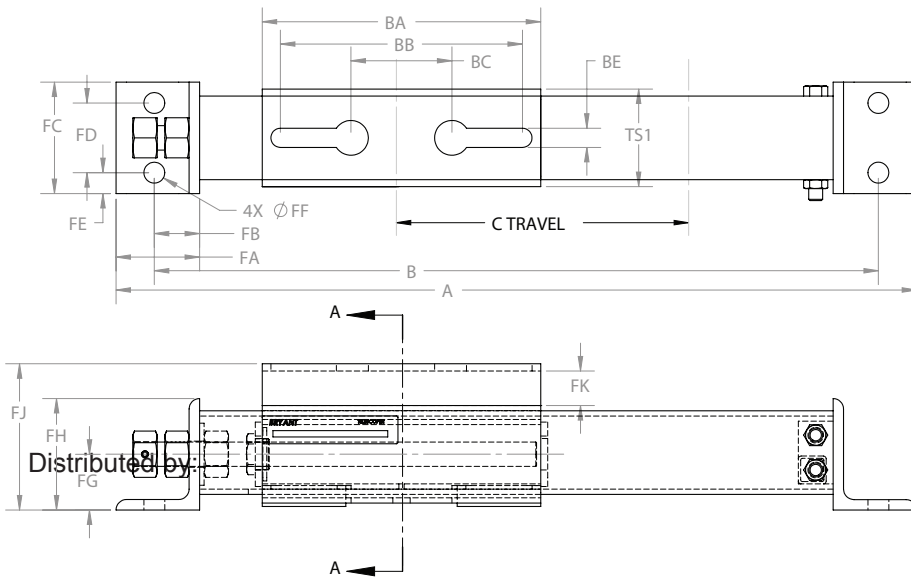

BEARING PLATE DIMENSIONS				
BA	BB	BC	BD	BE
10.00	8.69	5.56	0.69	1.75
14.00	11.75	8.50	1.00	2.00
22.00	per customer specifications			

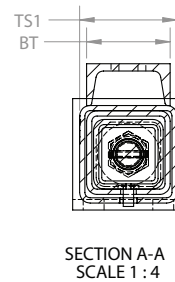

WARRANTY

Two year no freeze-up
guarantee standard
-or-
Five year no freeze-up
guarantee with addition
of grease fitting

ISO Certified for World Class Quality

Call 1-800-VAN-GORP for all of your conveyor pulley and take-up frame needs!

1410 Washington St
PO Box 288
Pella, IA 50219
www.vangorp.biz